

A-A

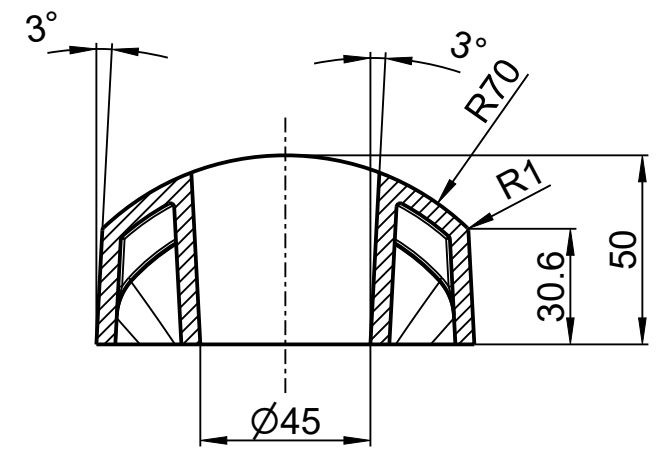

B-B

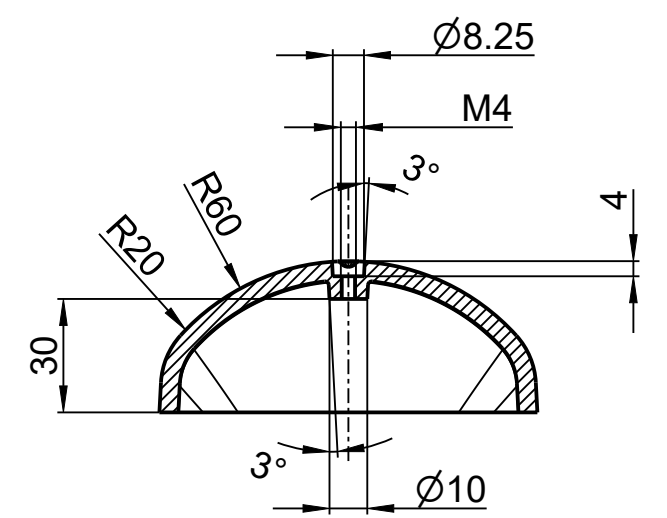

C-C

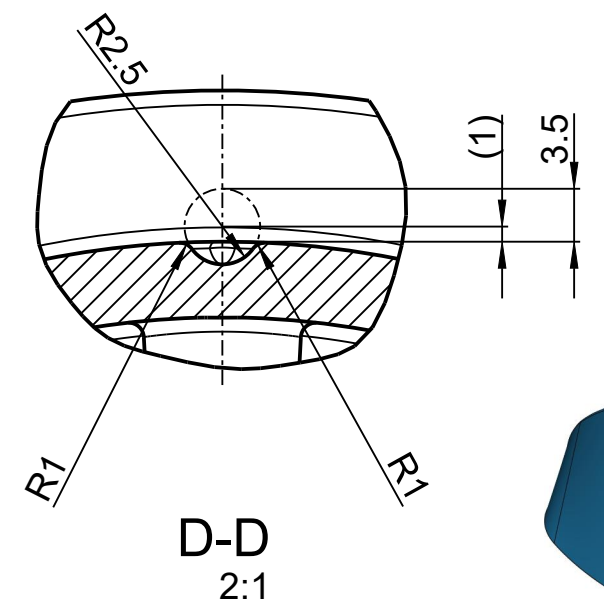
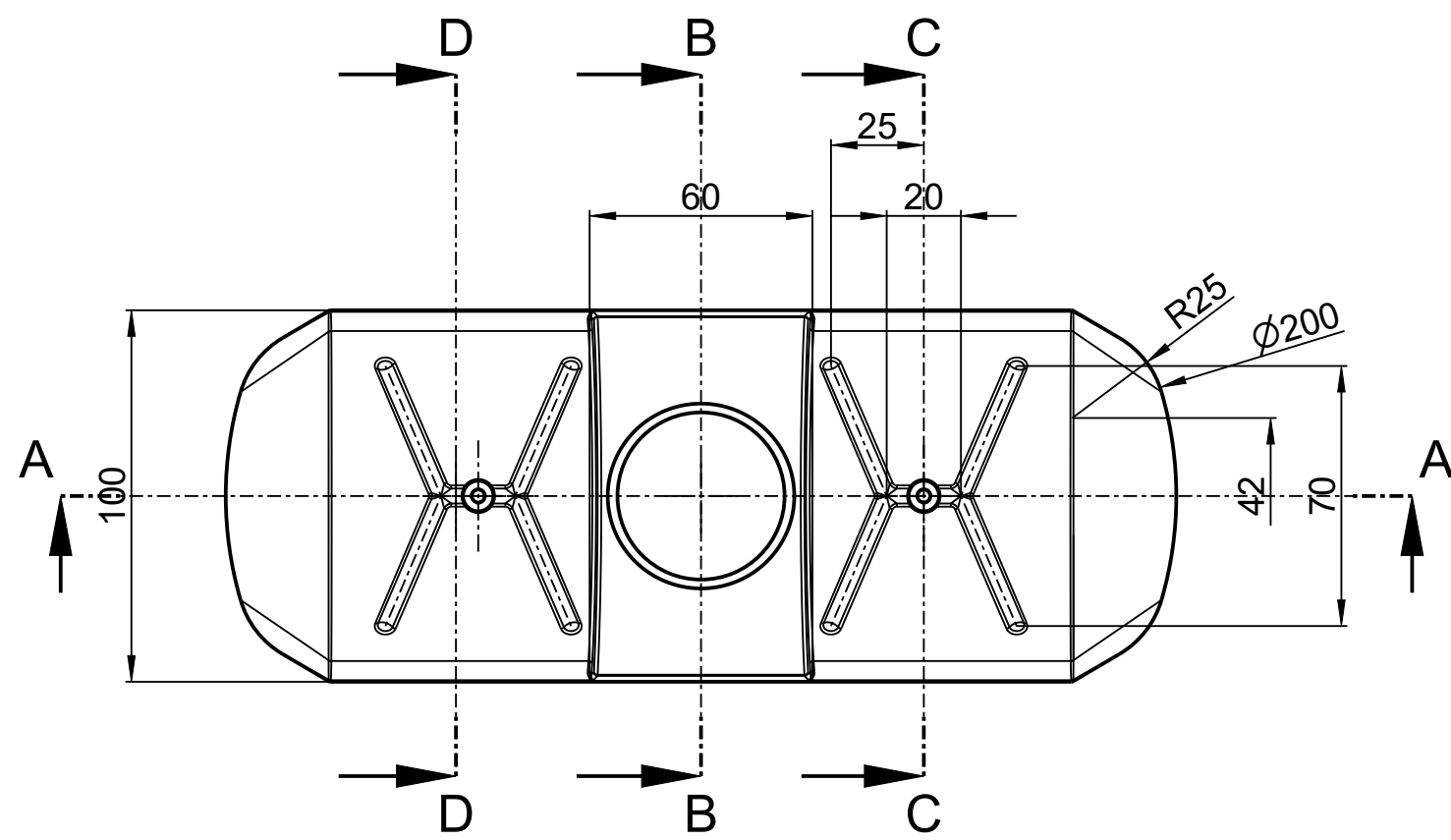

D-D  
2:1

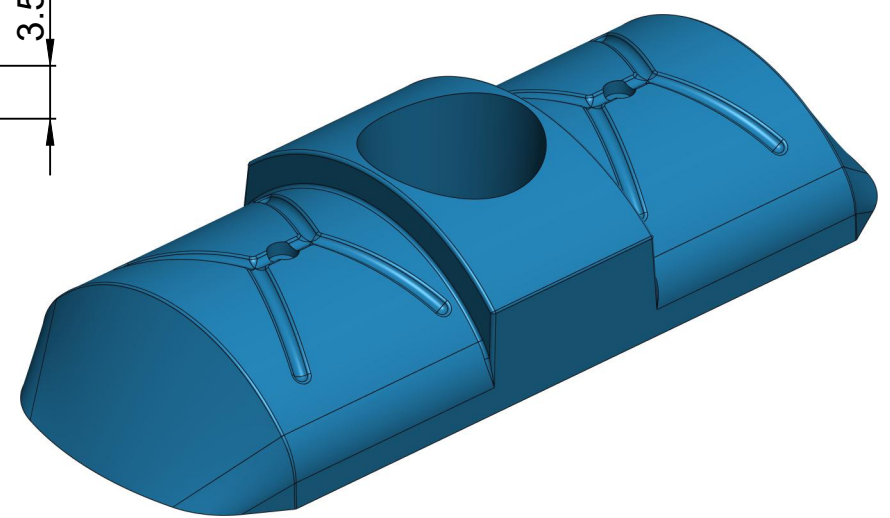

1:2

Wandstärke durchgehend 5.0

|                         |          |                                       |      |                        |   |                 |
|-------------------------|----------|---------------------------------------|------|------------------------|---|-----------------|
| Tolerierung<br>ISO 8015 |          | Allgemein-<br>toleranz<br>ISO 2768-mK |      | Kanten<br>ISO<br>13715 | Masstab: 1:2                                    | Gewicht: 1.6 kg |
|                         |          |                                       |      |                        | Werkstoff<br>Halbzeug<br>Rohteil - Nr. S235JRG2 |                 |
|                         |          |                                       |      | Datum                  | Name  |                 |
|                         |          |                                       |      | Bearb. 01.09.2023      | ARINDA  |                 |
|                         |          |                                       |      | Gepr.                  |   |                 |
|                         |          |                                       |      | Norm                   |   |                 |
|                         |          |                                       |      |                        | Benennung                                       |                 |
|                         |          |                                       |      |                        | Monatsaufgabe 09/2023                           |                 |
|                         |          |                                       |      |                        | Zeichnungsnummer                                |                 |
|                         |          |                                       |      |                        | KAPPE   |                 |
|                         |          |                                       |      |                        | Blatt   |                 |
|                         |          |                                       |      |                        | 1   |                 |
|                         |          |                                       |      |                        | 1   Bl  |                 |
| Zust.                   | Änderung | Datum                                 | Name | Urspr.                 | Ers. für:                                       | Ers. durch:     |